

## MISCELLAENOUS STACK EQUIPMENT

### WELDING ANGLE

Stainless steel angle for welding to steel stack to support air terminals or cable holders – may be bolted to steel surface with two 3/8" screws – made of 1/8" thick stainless steel 3" wide, 6" vertical leg, 4-5/8" horizontal leg of angle – holes to receive 1/4" anchor bolts on point base of metal mount series.

Cat. No. 470 - 13.8 oz.

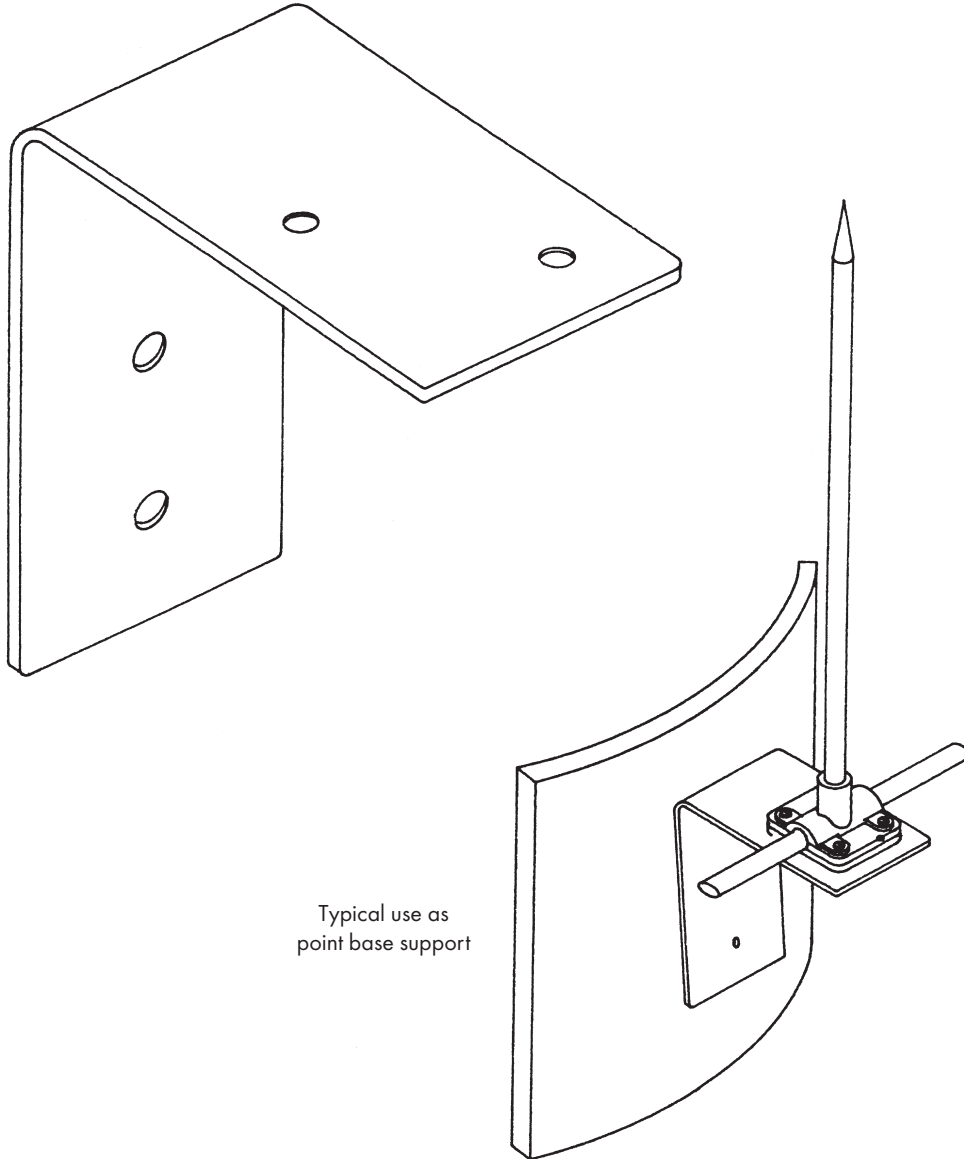

# ROBBINS LIGHTNING, INC.

124 EAST SECOND STREET PHONE (660) 582-3156 FAX (660) 582-3039 P.O. BOX 440 MARYVILLE, MISSOURI 64468-0440